

# > WC pack STANDARD SAMOA

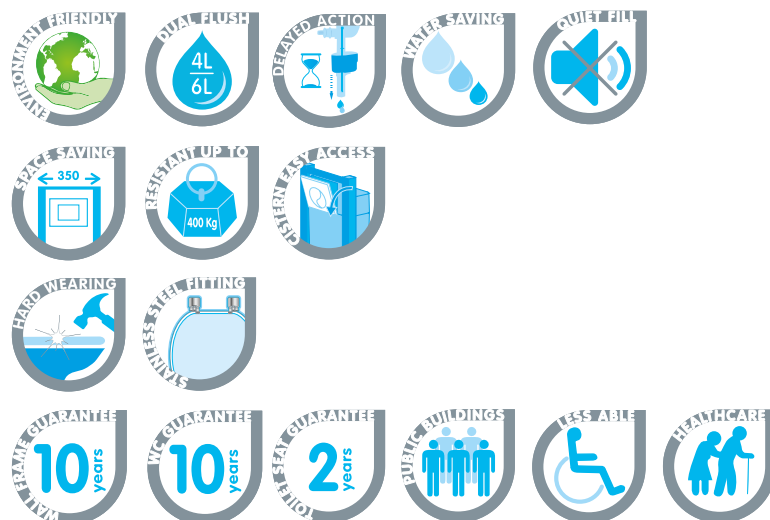

## DESCRIPTION

- ▶ BCM 350, wall fixing. Dual flush outlet valve, factory preset 6/4 litres flush, NF approved. Water saving and quiet fill delayed action inlet valve NF approved. Conforms to EN 14055 Class 2 flushing standards, BREEM requirements and UK Building Regulations. See page 19 for more details
- ▶ Front flush plate operation. Supplied with bright chrome Ying Yang, dual flush plate, NF approved (see page 47 for more details), WC connector and drainage set
- ▶ White wall hung ceramic WC Vitra Normus. Conforms to NF, EN 997 Class 2 flushing standards, BREEM requirements and UK Building Regulations
- ▶ White thermoplastic Opio Classic toilet seat, with stainless steel hinges, NF approved. See page 85 for more details



COMPLETE PACK IN 1 BOX

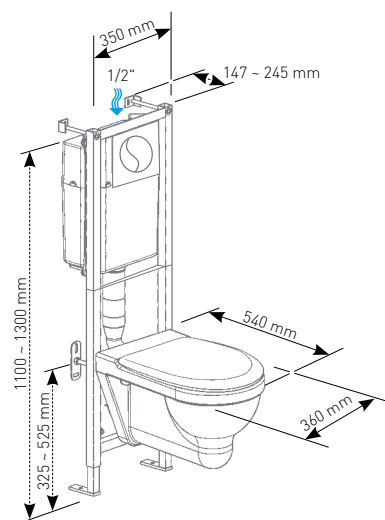

## TEXT FOR TENDERS:

### WC PACK STANDARD SAMOA Ref.: 31 1858 15

Complete pack comprising BCM 350 wall frame, 6 litre insulated cistern with NF approved components. Factory preset at 6/4 litres with integral dual flush outlet valve and a water saving and quiet fill delayed action inlet valve. Water inlet connection on the inside of the cistern fitted with an integral isolating valve. Front flush plate operation.

Supplied with fixing accessories for floor or wall fixing, dual flush plate, accessories for protection during the construction phase, ceramic wall hung WC, white thermoplastic toilet seat with stainless steel hinges, 90° outlet pipe and WC connectors.

	Ref.	Barcode	Packing	Packing			Pallet quantity
				Nb	M <sup>3</sup>	Kg	
WC pack STANDARD SAMOA	31 1858 15	3 24723 004059 9	Carton	1	0,131	38,00	15